

21" Portrait Digital Poster

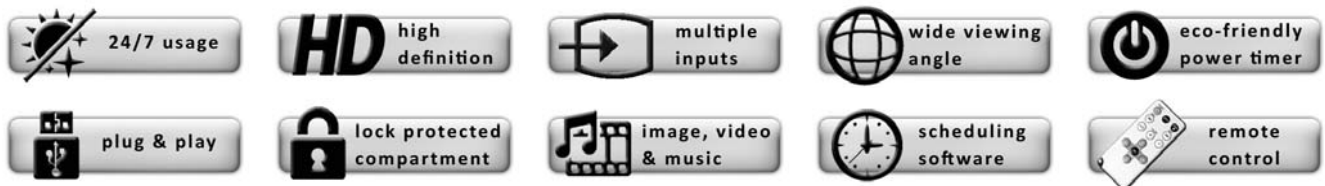

The newly updated, slimmer, range of Portrait Digital Posters offer a modern and stylish method of media display. They are a complete digital signage solution and thanks to their built in media player they require no additional hardware such as PCs, DVD players, excess cables or software; you simply plug and play.

Their sleek, elegant tempered glass styling, ability to be in constant use, wide viewing angle, high brightness and unbranded, buttonless design are just a few reasons why our Digital Posters are used over home TVs for commercial display. An eco-friendly power timer allows the user to set the display on and off times during a week, resulting in lower power consumption and running costs. A free portrait wall mount comes as standard.

Applications for these practical displays are diverse and include retail locations such as supermarkets, department stores, drug stores, show rooms and shopping centres as well as banks, bars, cafés, gyms, art galleries, salons, train/bus stations, travel agents, hospitals, schools, museums, exhibition displays, cinemas and conference halls.

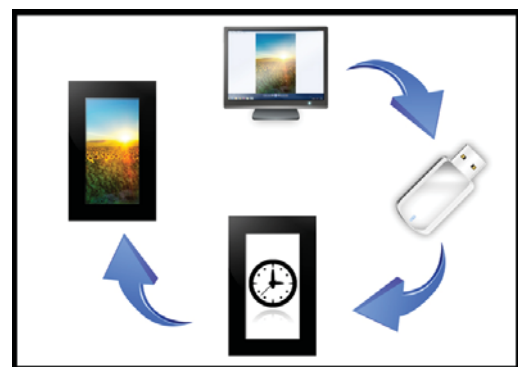

Our products use a straightforward plug and play system. Simply load the content in the order you want it to be displayed onto a USB stick. Insert the USB stick into the LCD screen, wait for the data to load, remove the USB stick and your images, videos and music will be displayed.

"The contemporary Digital Posters are an ideal replacement for static posters."

21" Portrait Digital Poster

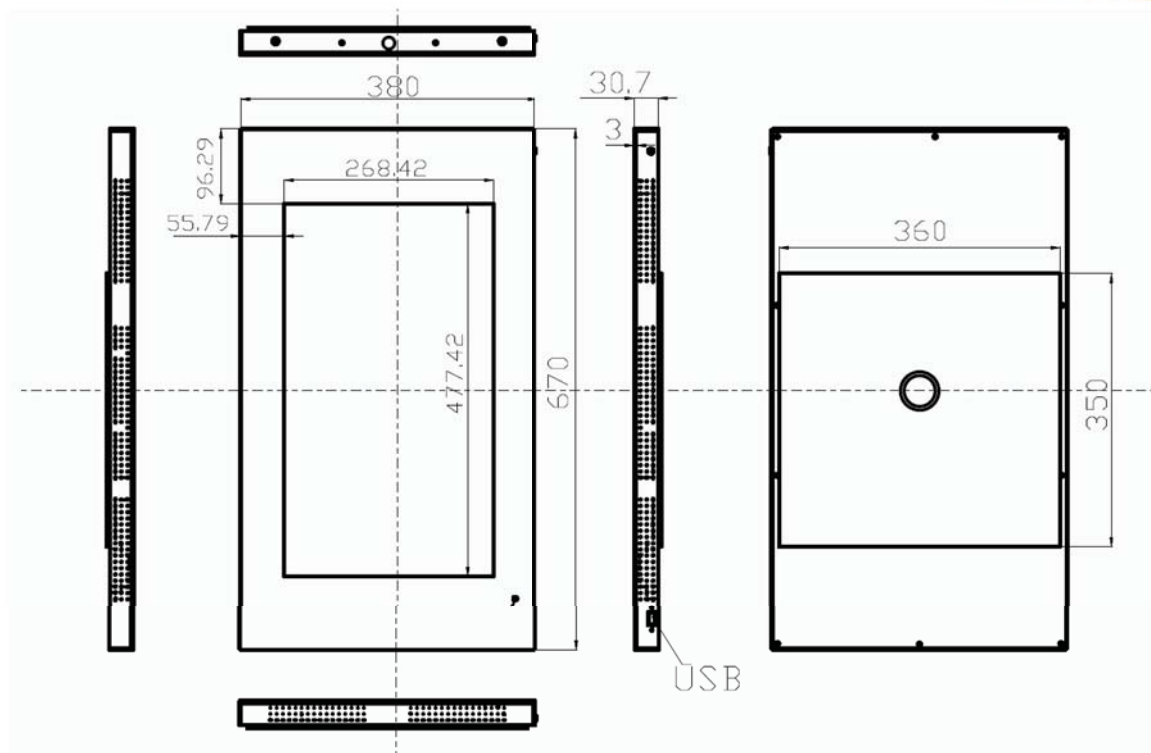

21" Portrait Digital Poster	
Display Size	21.6 Inch
Resolution	1366x768
Display Area (mm)	268.42x477.42
Aspect Ratio	16:9
Unit Size (WxHxD mm)	380x670x30.7
Package Size (WxHxD mm)	500x765x150
Wall Mount Size (mm)	360x480
Net Weight (kg)	10
Gross Weight (kg)	11.5
Brightness (cd/m ²)	300
Colour	16.7M
Viewing Angle	178°
Contrast Ratio	1000:1
Power Consumption (W)	65
Input Voltage	AC110~240V(50Hz~60Hz)
Working Temperature	0 °C to 50 °C
Media Formats	VIDEO (MPEG, AVI, Divx, Xvid, VOB), MP3, JPEG
Memory	2GB (Option for extra internal memory)
Port	USB 2.0
Accessories	Remote control, AC Power Cable, Scheduling Software CD, Key, User Manual, Wall Mount

"The contemporary Digital Posters are an ideal replacement for static posters."

21" Portrait Digital Poster



Although our Digital Advertising Displays can operate using the plug and play method and do not require any additional software, advanced users can utilize the Playlist Editor to create content schedules greatly expand the potential of the LCD Display for Digital Signage.

Playlist Editor has a user friendly layout and easy to follow steps. It allows the user to create timed schedules to which image, video and audio files can be added. Duration times and transition styles can also be set for each image or video file.



"The contemporary Digital Posters are an ideal replacement for static posters."