

# ABT Trapdoor ElectriScreen

---

The ABT Trapdoor was designed for large-scale applications in which the screen must completely go undetected when not in use

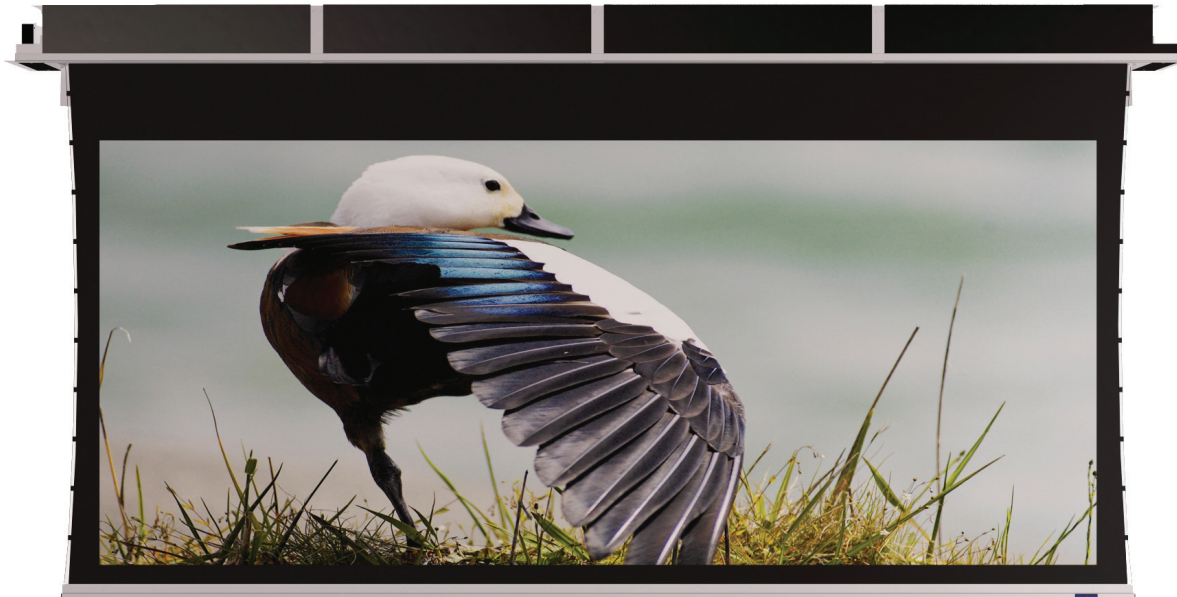

# ABT Trapdoor ElectriScreen

The ABT Trapdoor was designed for large-scale applications in which the screen must completely go undetected when not in use. This line of custom engineered retractable trapdoor screen models consist of the ABT-4 (3.25-inch roller tube) and ABT-6 (6-inch roller tube) in order to accommodate a various range of sizes.

The ABT Trapdoor is available with variety of Stewart's front or rear projection materials. Our exclusive Tab-Guy™ tensioning system ensures a smooth and completely flat screen surface. Matte black over-scan borders\* provide a perfectly masked image area.

Microperf X2 is available when acoustic transparency is required (acoustically transparent black drop also available upon request).

## SPECIFICATIONS

Electronically controlled screen system with trapdoor **Included**  
 Aluminum and sintra housing/case **Included**  
 3.25 or 6 inch roller tube with insulated drive **Included**  
 4 inch access panel **Included**  
 Tab-Guy™ tensioning system **Included**  
 Matte black over-scan border\* **Included**

## MATERIAL

Front projection material **Included**  
 Rear projection material **Optional**

## PERFORATIONS

Microperf X2 THX Ultra **Optional**  
 Acoustically transparent masking panels **Optional**

## MOUNTING

Recessed/ceiling **Included**  
 Factory set adjustable drywall flanges **Included**

## SCREEN MOTOR

120 Volt **Included**  
 220 Volt **Optional**

## SCREEN CONTROL

LVC (low voltage control - includes 3 button wall switch) **Included**  
 STI (12v screen trigger interface) **Optional**  
 IRR (IR remote) **Optional**  
 WRC (wireless RF remote) **Optional**

## CASE/HOUSING DIMENSIONS

ABT-4 case height **9.25" (235 mm)**  
 ABT-4 case depth **12.5" (318 mm)**  
 ABT-6 case height **11.25" in (286 mm)**  
 ABT-6 case depth **14.5" (368 mm)**

For custom sizes and gains, please consult the WebSA or your local Stewart representative.

## HDTV Format 1.78:1/16:9

Model #	Diagonal	Image Height	Image Width	Batten Length	Unit Weight	Max. Case Length
ABT4123H	123 (3124)	60 (1524)	107 (2718)	119 (3023)	155 (70)	134 (3404)
ABT4135H	135 (3429)	66 (1676)	118 (2997)	130 (3302)	160 (72)	145 (3683)
ABT4165H	165 (4191)	81 (2057)	144 (3658)	156 (3962)	170 (77)	171 (4343)
ABT4188H	188 (4775)	92 (2337)	164 (4166)	180 (4572)	270 (122)	213 (5410)
ABT6220H	220 (5588)	108 (2743)	122 (3099)	212 (5385)	370 (167)	245 (6223)

## NTSC Format 1.33:1/4:3

Model #	Diagonal	Image Height	Image Width	Batten Length	Unit Weight	Max. Case Length
ABT4150V	150 (3810)	90 (2286)	120 (3048)	132 (3353)	165 (74)	147 (3734)
ABT4180V	180 (4572)	108 (2743)	144 (3658)	162 (4415)	170 (77)	171 (4343)
ABT6210V	210 (5334)	126 (3200)	168 (4267)	190 (4826)	270 (122)	223 (5664)
ABT6240V	240 (6096)	144 (3658)	192 (4877)	218 (5537)	370 (167)	251 (6375)

\*It is important to add only the amount of black drop needed. Side and bottom masking determined by the amount of black drop and image size.

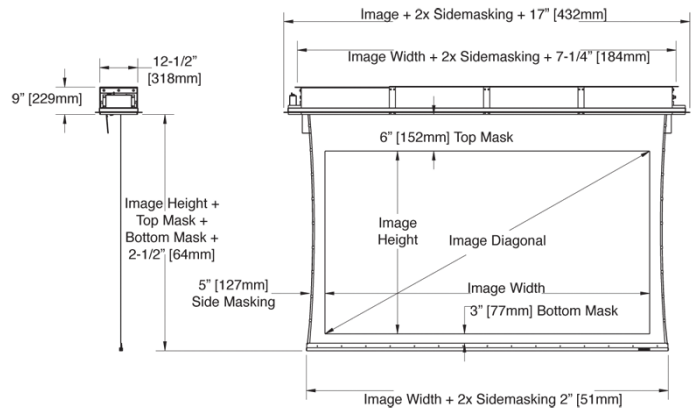

\*\*ABT Trapdoor ElectriScreen with 6" Roller Tube

