

CP-SX1350

Hitachi's CP-SX1350 uses 3LCD technology to provide true SXGA+ (1400 x 1050) resolution at 3500 ANSI Lumens. The CP-SX1350 has motorised optical lens shift and a wide range of interchangeable lenses for use in any environment.

- 3LCD Technology
- SXGA+ Resolution (1400 dots x 1050 lines)
- 3500 ANSI Lumens for High Brightness
- 1.5x Powered Zoom Lens
- 4 Optional Lenses (bayonet fitting)
- Full Connectivity
- Vertical Optical Lens Shift System (Lockable)
- Horizontal and Vertical Keystone Correction
- My Screen Option with Lock System
- Progressive Scan for smooth, flicker-free pictures
- PIN Security Protection
- Network Enabled (RJ45)
- HDCP Decoding
- HD Ready



Multi Function Controls



www.hitachidigitalmedia.com

CP-SX1350

Technical Specifications

HITACHI
Inspire the Next

OPTICAL

LCD Panel	0.99" P-Si TFT x 3 with Micro Lens
Resolution	1400 dots x 1050 lines
Lens/Projection Distance	Standard Lens (NL-500): (2.1-3.2m@70") F=1.7-2.4, f=31-46mm/Throw distance ratio= 1.5-2.2:1, Zoom: x 1.5 Option 1 - Short Fixed Lens (FL-501): (Only 1:1 lens shift) (1.1m@70") F=2.3, f=16mm/Throw distance ratio= 0.8:1, Zoom: x 1.0 Option 2 - Short Zoom Lens (SL-502): (1.6-2.1m@70") F=2.2-2.8, f=23-31mm/Throw distance ratio= 1.1-1.5:1, Zoom: x 1.3 Option 3 - Long Zoom Lens (LL-503): (3.2-5.9m@70") F=2.1-2.6, f=46-82mm/Throw distance ratio= 2.2-4.1:1, Zoom: x 1.8 Option 4 - Super Long Throw Lens (LL-504): (5.6-10.3m@70") F=2.2-3.0, f=80-144mm/Throw distance ratio=3.9-7.3:1, Zoom x 1.8
Lamp	310W UHB
Lamp Life	2000 hours
Brightness (Normal)	3500 ANSI Lumens
(Whisper)	2800 ANSI Lumens
Contrast Ratio	650:1 (typ)
Display Size	40-500" (standard lens)
Colour Saturation	X=0.310, Y=0.360
Colour	8 Bits/colour, 16.7M colours

COMPATIBILITY

Composite Video	NTSC, PAL (-BGDHI), SECAM, PAL-M, PAL-N, NTSC4.43, PAL 60
Component Video	SDTV: 525i (480i), 525p (480p), 625i (576i) HDTV: 750p (720p@50/60Hz), 1125i (1080i@50/60Hz)
Computer	IBM Compatible VGA, SVGA, XGA, SXGA, SXGA+, UXGA Capability, MAC 13", MAC 16" (PixelWorks Chip)
Plug & Play	DDC1/2B (VESA) for RGB Input; DDC2B for M1-D Input
Frequency Range	Horizontal: 15-106kHz (Video/PC) Vertical: 50-120Hz (Video/PC)

FEATURES

Keystone Correction	10:0-1:1 upward shift (Power lens shift)
Speakers	2 x 1W
Start Up Screen	My Screen with Lock System
Image Control	Electrical H & V Keystone
User Controls	Network function (for control projector), Replaceable lenses (Bayonet type), Picture in Picture, Variable Colour (R&B individual), Freeze function, Magnify (x4), Digital gamma correction, Progressive scan, PIN lock system, Unique ID via remote control, Auto adjust for computer & video signals
Agency Certifications	UL60950/C-UL, FCC Part 15, Class B, CE, TUV EN60950

CONNECTORS

Computer Input	1 x 15-pin Mini D-sub 1 x BNC (x5) (shared with component) 1 x M1-D (HDCP Decoding for digital video signal)
Computer Output	1 x 15-pin Mini D-sub (from selected computer input, 15-pin Mini D-sub or BNC)
Video Input	1 x RCA Jack 1 x S-Video Jack (4-pin Mini-DIN) 1 x RCA Jack (x3) for component 1 x BNC (x3) (shared with computer)
Audio Input	1 x RCA Jack (x2) for video 2 x Stereo Mini Jack for computer
Audio Output	1 x Stereo Mini Jack (selected out)
Control	1 x 9-pin D-sub for RS-232C (Serial)
Mouse	1 x USB (M1-D terminal)
Wired Remote Control	1 x Ø 3.5 dia Stereo Mini Jack
Network Interface	RJ45

POWER

Power Supply	100-120/220-240V AC, 50/60Hz, auto switching
Power Consumption	470W

PHYSICAL

Dimensions (W x H x D)	420 x 160 x 320mm (including feet and extrusions)
Weight	7.7Kg
Noise Level	42dB/38dB (whisper mode)

MISCELLANEOUS

Power, Lamp and Temperature Indicator Light, Input Indicator Light, Ceiling Mount Image, Rear Projection Image, Easy/Advanced OSD Menu (17 Languages), Power Zoom, Power Focus, Power Lens Shift, Lens Shift Lock, Remote Control can be "wired" to projector, HDCP Decoding for Digital Video Signal, My Memory (4 Settings), Optional Lens Auto Detection, Component/SCART, RGB Selection on BNC Port

ACCESSORIES SUPPLIED

Remote Control (with laser pointer, batteries)
M1-D Cable (conversion cable between M1-D & DVI & USB)
Power Cord
RGB Cable
Video Cable (for Audio/Video)
Safety Instructions (15 languages)
Quick Start Guide (14 languages)
User Manual (14 languages on CD: English, German, French, Italian, Spanish, Dutch, Norwegian, Portuguese, Korean, Simplified Chinese, Swedish, Russian, Finnish, Polish)

OPTIONAL ACCESSORIES

Replacement Lamp	DT00601
Optional Lenses	NL-500 (Standard), FL-501 (Short Fixed), SL-502 (Short Zoom), LL-503 (Long Zoom), LL-504 (Super Long Zoom)

Projector Management Software: FREE download from www.hitachidigitalmedia.com

All brand or product names are trademarks or registered trademarks of their respective owners.
Design and specifications are subject to change without notice.

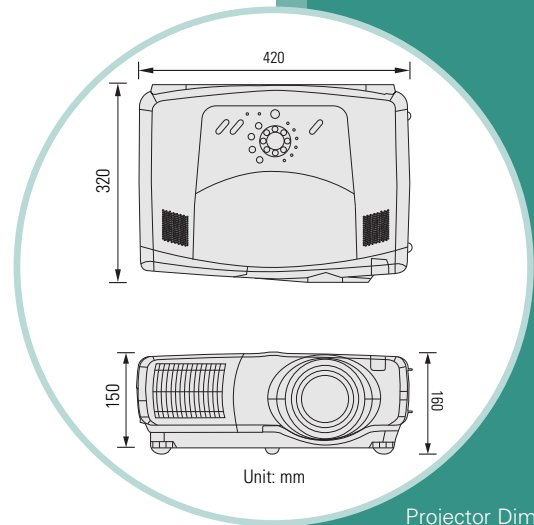

Projector Dimensions

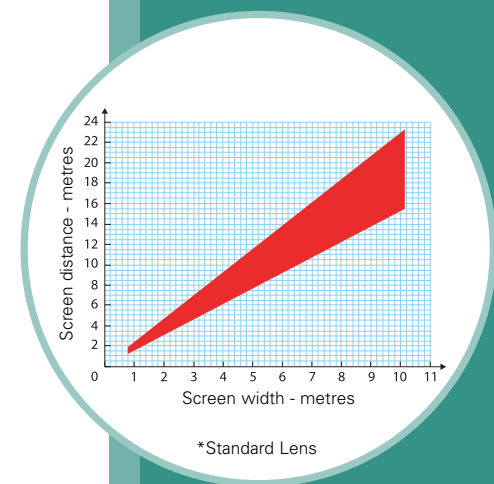

HITACHI DIGITAL MEDIA
Hitachi Europe Ltd
Whitebrook Park
Lower Cookham Road
Maidenhead
Berkshire SL6 8YA
United Kingdom

Tel: +44 (0)1628 585 000
Fax: +44 (0)1628 585 500
www.hitachidigitalmedia.com

The specification above and photography is for reference only and may be subject to change.